

*TB 9-6625-2293-24

DEPARTMENT OF THE ARMY TECHNICAL BULLETIN

CALIBRATION PROCEDURE FOR OSCILLOSCOPE TEKTRONIX, MODEL 2465

Headquarters, Department of the Army, Washington, DC
26 November 2007

Distribution Statement A: Approved for public release, distribution is unlimited.

REPORTING OF ERRORS AND RECOMMENDING IMPROVEMENTS

You can improve this manual. If you find any mistakes or if you know of a way to improve these procedures, please let us know. Mail your letter or DA Form 2028 (Recommended Changes to Publications and Blank Forms) directly to: Commander, U.S. Army Aviation and Missile Command, ATTN: AMSAM-MMC-MA-NP, Redstone Arsenal, AL 35898-5000. A reply will be furnished to you. You may also send in your comments electronically to our E-mail address: 2028@redstone.army.mil or by fax 256-842-6546/DSN 788-6546. For the World Wide Web use: <https://amcom2028.redstone.army.mil>. Instructions for sending an electronic 2028 can be found at the back of this manual.

SECTION		Paragraph	Page
I.	IDENTIFICATION AND DESCRIPTION		
	Test instrument identification	1	2
	Forms, records, and reports	2	2
	Calibration description	3	2
II.	EQUIPMENT REQUIREMENTS		
	Equipment required.....	4	3
	Accessories required	5	3
III.	CALIBRATION PROCESS		
	Preliminary instructions	6	4
	Equipment setup.....	7	4
	Low frequency response.....	8	6
	Vertical gain.....	9	6
	Triggering.....	10	9
	Timing.....	11	12
	Bandwidth	12	18
	Calibrator.....	13	20
	Final procedure	14	20
IV.	MENU CALIBRATION PROCESS		
	Preliminary instructions.....	15	20
	Equipment setup.....	16	21

*This technical bulletin supersedes TB 9-6625-2293-35, dated 7 October 2003.

	Paragraph	Page
Power supply.....	17	22
DAC REF and input capacitance.....	18	22
CAL 01 horizontal.....	19	24
CAL 02 vertical.....	20	27
CAL 03 triggering.....	21	30
CAL 06 vertical transient response.....	22	30
Final procedure.....	23	33

**SECTION I
IDENTIFICATION AND DESCRIPTION**

1. Test Instrument Identification. This bulletin provides instructions for the calibration of Oscilloscope, Tektronix, Type 2465. The manufacturer's manual was used as the prime data source in compiling these instructions. The equipment being calibrated will be referred to as the TI (test instrument) throughout this bulletin.

a. Model Variations. None.

b. Time and Technique. The time required for this calibration is approximately 6 hours, using the dc and low frequency technique.

2. Forms, Records, and Reports

a. Forms, records, and reports required for calibration personnel at all levels are prescribed by TB 750-25.

b. Adjustments to be reported are designated (R) at the end of the sentence in which they appear. Report only those adjustments made and designated with (R).

3. Calibration Description. TI parameters and performance specifications which pertain to this calibration are listed in table 1.

Table 1. Calibration Description

Test instrument parameters	Performance specifications
<u>Vertical gain</u>	
CH1 and CH2	Range: 2 mV/div to 5 V/div Accuracy: ±2%
Delta V cursors CH 3 and CH 4	Accuracy: ±(1.25% of reading +.03 div) Range: 0.1 and 0.5 V/div Accuracy: ±10%
<u>Trigger CH 1 and CH 2</u>	
Level readout	Accuracy: Within ± [3% of setting +3% of p-p signal +0.2 division +(0.5 mV x probe attenuation factor)]
Sensitivity Dc coupled	0.35 division dc to 50 MHz 1.0 division at 500 MHz
Ac coupled	0.35 division 60 Hz to 50 MHz 1.0 division at 500 MHz

Table 1. Calibration Description - Continued

Test instrument parameters	Performance specifications	
<u>Timing</u>		
A sweep	Range: 500 ms/div to 5 ns/div extended to 0.5 ns with X10 mag Accuracy: 500 and 200 ms/div \pm (1.2% of time interval + 0.6% of FS) 100 ms to 5 ns/div \pm (0.7% of time interval + 0.6% of FS) X10 mag: \pm (1.2% of time interval + 0.6% of FS)	
B Sweep	Range: 50 ms/div to 5 ns/div extended to 0.5 ns with X10 mag Accuracy: \pm (0.7% of time interval + 0.6% of FS) X10 mag: \pm (1.2% of time interval + 0.6% of FS)	
A sweep delta time with cursors	Accuracy: \pm (0.5% of time interval + 0.3% of FS) X10 mag: \pm (1% of time interval + 0.3 % of FS)	
Delta time with sweep delay	Accuracy: \pm (0.3% of time interval + 0.1% of FS)	
Delay sweep	Accuracy: \pm (0.3% of delay setting + 0.6% of FS) + 0 to -25 ns	
<u>Frequency Response</u>	VOLTS/DIV switch setting	With internal 50 Ω termination
3 dB bandwidth CH 1 and CH 2	2 mV 5 mV or greater	Dc to 100 MHz Dc to 300 MHz
-4.7 dB bandwidth CH 3 and CH 4	0.1 V or 0.5 V	Dc to 300 MHz
Ac coupled lower -3 dB point	10 Hz or less	
<u>Calibrator</u>		
Output voltage	Range: 0.4 V Accuracy: \pm 1% into 1 M Ω load	
Repetition period	Range: two times the A SEC/DIV setting for SEC/DIV from 200 ns to 200 ms Accuracy: \pm 0.1%, during sweep time	

SECTION II EQUIPMENT REQUIREMENTS

4. Equipment Required. Table 2 identifies the specific equipment to be used in this calibration procedure. This equipment is issued with Secondary Transfer Calibration Standards Sets AN/GSM-286, AN/GSM-287 or AN/GSM-705. Alternate items may be used by the calibrating activity. The items selected must be verified to perform satisfactorily prior to use and must bear evidence of current calibration. The equipment must meet or exceed the minimum use specifications listed in table 2. The accuracies listed in table 2 provide a four-to-one ratio between the standard and TI. Where the four-to-one ratio cannot be met, the actual accuracy of the equipment selected is shown in parenthesis.

5. Accessories Required. The accessories required for this calibration are common usage accessories issued as indicated in paragraph 4 above and are not listed in this calibration procedure. The following peculiar accessories are also required for this calibration: Standardizer, 5 – 80 pF; BNC plug to BNC jack (7916146).

Table 2. Minimum Specifications of Equipment Required

Common name	Minimum use specifications	Manufacturer and model (part number)
MULTIMETER	Range: 0 to 20 V Accuracy: $\pm 0.025\%$	Fluke, Model 8840A/AF05 (AN/GSM-64D)
OSCILLOSCOPE CALIBRATOR	Volts out: Range: 10 mV to 20 V Accuracy: $\pm 0.5\%$ Time markers: Range: 0.5 ns to 0.5 s Accuracy: $\pm 0.175\%$ Pulses: Risetime: ± 0.225 ns Sine wave frequency: Range: 1 Hz to 500 MHz	Fluke, Model 5820A-5C-GHZ (5820A-5C-GHZ)

SECTION III CALIBRATION PROCESS

6. Preliminary Instructions

a. The instructions outlined in paragraphs 6 and 7 are preparatory to the calibration process. Personnel should become familiar with the entire bulletin before beginning the calibration.

b. Items of equipment used in this procedure are referenced within the text by common name as listed in table 2.

c. Unless otherwise specified, verify the results of each test and, whenever the test requirement is not met, take corrective action before continuing with the calibration. Adjustments required to calibrate the TI are included in this procedure. Additional maintenance information is contained in the manufacturer's manual for this TI.

d. When indications specified in paragraphs 7 through 13 are not within tolerance, perform SECTION IV, MENU CALIBRATION PROCESS. After adjustments are made, repeat paragraphs 7 through 13. Do not perform SECTION IV if all other parameters are within tolerance.

e. Unless otherwise specified, all controls and control settings refer to the TI.

7. Equipment Setup

WARNING

HIGH VOLTAGE is used or exposed during the performance of the calibration. DEATH ON CONTACT may result if personnel fail to observe safety precautions. REDUCE OUTPUT(S) to minimum after each step within the performance check where applicable.

a. Connect TI to a 115 V ac source.

NOTE

When **POWER** pushbutton is pressed to **ON**, TI automatically performs a self-test sequence. Upon successful completion of self-test, TI will be in normal operating mode.

- b. Press **POWER** pushbutton to **ON** and allow at least 20 minutes for equipment warm-up.

NOTE

If TI crt displays **DIAGNOSTIC, PUSH A/B TRIG TO EXIT** at power on, one of the power-up tests has failed. If the error message on the bottom line of the display is **TEST 04 FAIL xx** where **xx** is **01, 02, 10, or 11**, stored calibration data is in error. If this error message is displayed, press **A/B TRIG** pushbutton to exit diagnostic mode and perform **SECTION IV**. If any other error message occurs, the failure is probably not related to calibration. In this case, the instrument should be repaired before attempting calibration.

- c. Press corresponding pushbutton for indications as listed in (1) through (9) below:

- (1) **VERTICAL MODE CH 1** and **CH 2** on.
- (2) **VERTICAL MODE CH 3** and **CH 4** off.
- (3) **VERTICAL MODE ADD** and **INVERT** off.
- (4) **VERTICAL MODE CHOP/ALT** to **ALT**.
- (5) **20 MHz BW LIMIT** to off.
- (6) **TRACK/INDEP** to **INDEP**.
- (7) **TRIGGER SLOPE** to + (plus).
- (8) **ΔV** and **Δt** off (cursors off).
- (9) **X10 MAG** to off (out).

- d. Set corresponding switches for indications as listed in (1) through (4) below:

- (1) **TRIGGER MODE** up to **AUTO LVL**.
- (2) **TRIGGER SOURCE** up to **VERT**.
- (3) **TRIGGER COUPLING** up to **DC**.
- (4) **CH 1** and **CH 2** input coupling up to **1 M Ω AC**.

- e. Position controls as listed in (1) through (10) below:

- (1) **VERTICAL POSITION** to midrange.
- (2) **CH 1** and **CH 2 VOLTS/DIV** to **100 mV** and **VAR** control cw to detent.
- (3) **A SWP** and **B SWP SEC/DIV** to **1 ms** (knobs locked).
- (4) **SEC/DIV VAR** cw to detent.
- (5) Horizontal **POSITION** to midrange.
- (6) **TRIGGER LEVEL** to midrange.

TB 9-6625-2293-24

- (7) **TRIGGER HOLDOFF** fully ccw to **MIN**.
 - (8) **TRACE SEP** fully cw.
 - (9) **SCALE ILLUM** fully ccw.
 - (10) **INTENSITY**, **FOCUS**, and **READOUT INTENSITY** for suitable viewing.
- f. Press **VERTICAL MODE CH 2** pushbutton to off (out).

8. Low Frequency Response

a. Performance Check

- (1) Connect oscilloscope calibrator **SOURCE/MEASURE CHAN 1** to **TI CH 1** and oscilloscope calibrator **SOURCE/MEASURE CHAN 2** to **TI CH 2**.
- (2) Set oscilloscope calibrator for a **CHAN 1, WAVE GEN sine** mode output of **50 kHz** and adjust amplitude for 6 divisions of vertical display on **TI**.

NOTE

Set **A SWP SEC/DIV** switch as necessary to view signal.

NOTE

To perform step below, press oscilloscope calibrator **EDIT FIELD** pushbutton as required to place underline under one of the frequency digits.

- (3) Decrease oscilloscope calibrator frequency until display is 4.2 divisions. If oscilloscope calibrator frequency is not 10 Hz or less perform **b** below.
- (4) Press **TI VERTICAL MODE CH 1** pushbutton off and **VERTICAL MODE CH 2** pushbutton on and change oscilloscope calibrator output from **CHAN 1** to **CHAN 2**.
- (5) Repeat technique of (2) and (3) above for **CH 2**.
- (6) Disconnect equipment setup.

b. Adjustments. Perform **SECTION IV** below.

9. Vertical Gain

a. Performance Check

- (1) Press **VERTICAL MODE CH 1** pushbutton on and **VERTICAL MODE CH 2, 3, and 4** pushbuttons to off.
- (2) Press **20 MHz BW LIMIT** pushbutton on.
- (3) Set **CH 1** and **CH 2** input coupling switches down to **1 M Ω DC**.
- (4) Set **A SWP SEC/DIV** switch to **1 ms**.
- (5) Set **CH 1 VOLTS/DIV** switch to **2 mV**.
- (6) Push up and momentarily hold both **CH 1** and **CH 2** input coupling switches in their **1 M Ω AC** position until a moving dot display replaces the normal signal and readout displays **DC BALANCE IN PROGRESS**. This performs a dc balance of **CH 1** and **CH 2**.

(7) When signal and readout displays automatically return to normal, set **CH 1** and **CH 2** input coupling switches down to **1 M Ω DC**.

(8) Connect oscilloscope calibrator **SOURCE/MEASURE CHAN 1-4** outputs to **TI CH 1-4** inputs respectively.

(9) Set oscilloscope calibrator for a **CHAN 1, VOLTAGE** mode output of **10 mV** at 1 kHz frequency.

(10) Rotate oscilloscope calibrator knob below **EDIT FIELD** pushbutton to adjust amplitude for 5 divisions of deflection on **TI**. If oscilloscope calibrator **Err** display does not indicate within limits specified in first row of table 3, perform **b** below.

(11) Repeat technique of (5), (9) and (10) above for settings listed in table 3. If oscilloscope calibrator **Err** display does not indicate within limits specified in table 3, perform **b** below.

Table 3. Vertical Gain CH 1

Test instrument		Oscilloscope calibrator		
VOLTS/DIV switch settings	Vertical deflection (divisions)	CHAN 1 VOLTAGE output		Err display Indication (%)
2 mV	5	10	mV	± 2
5 mV	4	20	mV	± 2
10 mV	5	50	mV	± 2
20 mV	5	0.1	V	± 2
50 mV	4	0.2	V	± 2
100 mV	5	0.5	V	± 2
200 mV	5	1.0	V	± 2
500 mV	4	2.0	V	± 2
1.0 V	5	5.0	V	± 2
2.0 V	5	10.0	V	± 2
5.0 V	4	20.0	V	± 2

(12) Press **VERTICAL MODE CH 2** pushbutton on and **VERTICAL MODE CH 1** off.

(13) Set **CH 2 VOLTS/DIV** switch to **2 mV**.

(14) Set oscilloscope calibrator for a **CHAN 2, VOLTAGE** mode output of **10 mV** at 1 kHz frequency.

(15) Rotate oscilloscope calibrator knob below **EDIT FIELD** pushbutton to adjust amplitude for 5 divisions of deflection on **TI**. If oscilloscope calibrator **Err** display does not indicate within limits specified in first row of table 4, perform **b** below.

(16) Repeat technique of (13) through (15) above for settings listed in table 4. If oscilloscope calibrator **Err** display does not indicate within limits specified in table 4, perform **b** below.

Table 4. Vertical Gain CH 2

Test instrument		Oscilloscope calibrator	
VOLTS/DIV switch settings	Vertical deflection (divisions)	CHAN 2 VOLTAGE output	Err display Indication (%)
2 mV	5	10 mV	± 2
5 mV	4	20 mV	± 2
10 mV	5	50 mV	± 2
20 mV	5	0.1 V	± 2
50 mV	4	0.2 V	± 2
100 mV	5	0.5 V	± 2
200 mV	5	1.0 V	± 2
500 mV	4	2.0 V	± 2
1.0 V	5	5.0 V	± 2
2.0 V	5	10.0 V	± 2
5.0 V	4	20.0 V	± 2

(17) Press **VERTICAL MODE CH 2** pushbutton off and **VERTICAL MODE CH 3** pushbutton on.

(18) Press **CH 3 VOLTS/DIV** pushbutton out to display **.1 V** on crt.

(19) Set oscilloscope calibrator for a **CHAN 3, VOLTAGE** mode output of **0.5 V** at 1 kHz frequency. If waveform displayed is not between 4.5 and 5.5 divisions, perform **b** below.

(20) Press **CH 3 VOLTS/DIV** pushbutton in to display **.5 V** on crt.

(21) Change oscilloscope calibrator output amplitude to 2 V. If waveform displayed is not between 3.6 and 4.4 divisions, perform **b** below.

(22) Press **VERTICAL MODE CH 3** pushbutton off and **VERTICAL MODE CH 4** pushbutton on.

(23) Press **CH 4 VOLTS/DIV** pushbutton out to display **.1 V** on crt.

(24) Set oscilloscope calibrator for a **CHAN 4, VOLTAGE** mode output of **0.5 V** at 1 kHz frequency. If waveform displayed is not between 4.5 and 5.5 divisions, perform **b** below.

(25) Press **CH 4 VOLTS/DIV** pushbutton in to display **.5 V** on crt.

(26) Change oscilloscope calibrator output amplitude to 2 V. If waveform displayed is not between 3.6 and 4.4 divisions, perform **b** below.

(27) Press **VERTICAL MODE CH 1** pushbutton on and **VERTICAL MODE CH 2, 3, and 4** off.

(28) Set oscilloscope calibrator for a **CHAN 1, VOLTAGE** mode output of **10 mV** at 1 kHz frequency.

(29) Press **ΔV** pushbutton to indicate **ΔV** (cursors on).

(30) Set **CH I VOLTS/DIV** switch to **2 mV** and adjust **CH 1 VERTICAL POSITION** control to center waveform on display.

(31) Adjust **ΔREF OR DLY POS** control to align reference cursor with bottom of waveform.

(32) Adjust **Δ** control to align **Δ** cursor with top of waveform. If **ΔV** readout does not indicate within limits specified in first row of table 5, perform **b** below.

(33) Repeat technique of (28) and (30) through (32) above for settings listed in table 5. If ΔV readout does not indicate within limits specified in table 5, perform **b** below.

Table 5. Delta Volts with Cursors

Test instrument VOLTS/DIV switch settings	Oscilloscope calibrator output settings	Test instrument ΔV readout indications	
		Min	Max
2m V	10 mV	9.81 mV	10.20 mV
5 mV	20 mV	19.6 mV	20.4 mV
10 mV	50 mV	49.0 mV	50.9 mV
20 mV	0.1 V	98.1 mV	102.0 mV
50 mV	0.2 V	196 mV	204 mV
100 mV	0.5 V	490 mV	509 mV
200 mV	1.0 V	0.981 V	1.02 V
500 mV	2.0 V	1.96 V	2.04 V
1.0 V	5.0 V	4.90 V	5.09 V
2.0 V	10.0 V	9.81 V	10.2 V
5.0 V	20.0 V	19.6 V	20.4 V

b. Adjustments. Perform **SECTION IV** below.

10. Triggering

a. Performance Check

- (1) Press ΔV pushbutton to off (cursors off).
- (2) Push **TRIGGER MODE** switch down to **NORM**.
- (3) Set oscilloscope calibrator for a **CHAN 1, VOLTAGE** mode output of **10 mV** at 1 kHz frequency.
- (4) Set **CH 1 VOLTS/DIV** switch to **2 mV**.
- (5) Adjust **TRIGGER LEVEL** control for most positive voltage that produces a barely triggered display for both + and - **SLOPE**. If **A TRIGGER LEVEL** readout indication is not within limits specified in + peak column of table 6 for 2 mV setting, perform **b** below.
- (6) Adjust **TRIGGER LEVEL** control for most negative voltage that produces a barely triggered display for both + and - **SLOPE**. If **A TRIGGER LEVEL** readout indication is not within limits specified in - peak column of table 6 for 2 mV setting, perform **b** below.
- (7) Repeat technique of (5) and (6) above for remaining **VOLTS/DIV** switch settings and oscilloscope calibrator outputs listed in table 6.

Table 6. A Trigger Level Readout

Test instrument VOLTS/DIV switch settings	Oscilloscope calibrator output settings	Test instrument trigger level readout indications			
		+ Peak		- Peak	
		Min	Max	Min	Max
2 mV	10 mV	8.5 mV	11.5 mV	-1.2 mV	1.2 mV
5 mV	20 mV	17.3 mV	22.7 mV	-2.1 mV	2.1 mV
10 mV	50 mV	44.5 mV	55.5 mV	-4.0 mV	4.0 mV
20 mV	0.1 V	89 mV	111 mV	-7.5 mV	7.5 mV
50 mV	0.2 V	177 mV	223 mV	-17 mV	17 mV
100 mV	0.5 V	449 mV	551 mV	-36 mV	36 mV
200 mV	1.0 V	0.90 V	1.10 V	-70 mV	70 mV
500 mV	2.0 V	1.78 V	2.22 V	-.14 V	.14 V
1.0 V	5.0 V	4.50 V	5.50 V	-.35 V	.35 V
2.0 V	10.0 V	9.0 V	11.0 V	-0.7 V	0.7 V
5.0 V	20.0 V	17.8 V	22.2 V	-1.4 V	1.4 V

(8) Set oscilloscope calibrator for a **CHAN 1, VOLTAGE** mode output of **10 mV** at 1 kHz frequency and set **TI CH 1 VOLTS/DIV** switch to **2 mV**.

(9) Pull **SEC/DIV** knob out and press **A/B TRIG** pushbutton for **B TRIGGER** and push **TRIGGER MODE** down for **TRIG AFT DLY**. Adjust **TRIGGER LEVEL** for a stable display.

(10) Adjust **ΔREF OR DLY POS** control for a delay readout of **0.000 ms**.

(11) Adjust **TRIGGER LEVEL** control for most positive voltage that produces an intensified point on waveform display for both + and - **SLOPE**. If **B TRIGGER** level readout indication is not within limits specified in + peak column of table 7 for 2 mV setting, perform **b** below.

(12) Adjust **TRIGGER LEVEL** control for most negative voltage that produces an intensified point on waveform display for both + and - **SLOPE**. If **B TRIGGER** level readout indication is not within limits specified in - peak column of table 7 for 2 mV setting, perform **b** below.

(13) Repeat technique of (8) and (10) through (12) above for each remaining **VOLTS/DIV** switch setting and oscilloscope calibrator output listed in table 7.

Table 7. B Trigger Level Readout

Test instrument VOLTS/DIV switch settings	Oscilloscope calibrator output settings	Test instrument trigger level readout indications			
		+ Peak		- Peak	
		Min	Max	Min	Max
2 mV	10 mV	8.5 mV	11.5 mV	-1.2 mV	1.2 mV
5 mV	20 mV	17.3 mV	22.7 mV	-2.1 mV	2.1 mV
10 mV	50 mV	44.5 mV	55.5 mV	-4.0 mV	4.0 mV
20 mV	0.1 V	89 mV	111 mV	-7.5 mV	7.5 mV
50 mV	0.2 V	177 mV	223 mV	-17 mV	17 mV
100 mV	0.5 V	449 mV	551 mV	-36 mV	36 mV

Table 7. B Trigger Level Readout - Continued

Test instrument VOLTS/DIV switch settings	Oscilloscope calibrator output settings	Test instrument trigger level readout indications			
		+ Peak		- Peak	
		Min	Max	Min	Max
200 mV	1.0 V	0.90 V	1.10 V	-70 mV	70 mV
500 mV	2.0 V	1.78 V	2.22 V	-.14 V	.14 V
1.0 V	5.0 V	4.50 V	5.50 V	-.35 V	.35 V
2.0 V	10.0 V	9.0 V	11.0 V	-0.7 V	0.7 V
5.0 V	20.0 V	17.8 V	22.2 V	-1.4 V	1.4 V

- (14) Reduce outputs to minimum and disconnect equipment setup.
- (15) Press **TRIGGER SLOPE** pushbutton for + (plus).
- (16) Set **TRIGGER COUPLING** switch down to **AC**.
- (17) Set **TRIGGER MODE** switch up to **RUN AFT DLY** then press **A/B TRIG** pushbutton and set **TRIGGER MODE** switch up to **AUTO LVL**.
- (18) Set **CH 1 VOLTS/DIV** switch to **10 mV** and **A SWP SEC/DIV** switch to **10 ms** (knob locked).
- (19) Connect oscilloscope calibrator **SOURCE/MEASURE CHAN 1** and **2** outputs to **TI CH 1** and **2** inputs respectively.
- (20) Set oscilloscope calibrator for a **CHAN 1, WAVE GEN (WAVE sine)** mode output **35 mV** at a 60 Hz frequency, and adjust amplitude for 3.5 divisions of vertical display on TI.
- (21) Set **CH 1 VOLTS/DIV** switch to **100 mV** and adjust **TRIGGER LEVEL** control for a stable display. If a stable display cannot be obtained, perform **b** below.

NOTE

Set **A SWP SEC/DIV** switch and press **X10 MAG** pushbutton as necessary to obtain a well-defined display of test signal.

- (22) Insert a 50 Ω feedthrough termination into connection.
- (23) Set **CH 1 VOLTS/DIV** switch to **10 mV** and press **20 MHz BW LIMIT** to off.
- (24) Set oscilloscope calibrator for a **CHAN 1, LEVEL SINE** mode output of **50 MHz** and adjust amplitude for 3.5 divisions of vertical display on TI.
- (25) Set **CH 1 VOLTS/DIV** switch to **100 mV** and adjust **TRIGGER LEVEL** control for a stable display. If a stable display cannot be obtained, perform **b** below.
- (26) Remove 50 Ω feedthrough termination from connection.
- (27) Set **TRIGGER COUPLING** switch up to **DC** and repeat technique of (20) through (26) above.
- (28) Set oscilloscope calibrator for a **CHAN 1, LEVEL SINE** mode output of **500 MHz** and adjust amplitude for 1.0 division of vertical display on TI.
- (29) Adjust **TRIGGER LEVEL** control for a stable display. If a stable cannot be obtained perform **b** below.

TB 9-6625-2293-24

(30) Set **TRIGGER COUPLING** switch up to **AC** and repeat technique of (28) and (29) above.

(31) Press **VERTICAL MODE CH 1** pushbutton off and **VERTICAL MODE CH 2** pushbutton on.

(32) Change oscilloscope calibrator active output from **CHAN 1** to **CHAN 2**.

(31) Repeat technique of (16) through (30) above for **CH 2**.

b. Adjustments. Refer to **SECTION IV** below.

11. Timing

a. Performance Check

(1) Press **VERTICAL MODE CH 1** on and **VERTICAL MODE CH 2, 3,** and **4** off.

(2) Set **TRIGGER COUPLING** switch up to **DC**.

(3) Press **X10 MAG** pushbutton to off.

(4) Set oscilloscope calibrator for a **CHAN 1, MARKER** mode output of **5 ns /div**.

(5) Set **A SWP SEC/DIV** switch to **5 ns** (knobs locked).

(6) Set **CH 1 VOLTS/DIV** switch for approximately 2 divisions of display.

(7) Adjust **TRIGGER LEVEL** control for a stable display.

(8) Adjust horizontal **POSITION** control to align 2^d time marker with 2^d vertical graticule line.

(9) Rotate oscilloscope calibrator knob located below **EDIT FIELD** pushbutton to align 10th time marker with 10th vertical graticule line. If oscilloscope calibrator **Err** display and TI linearity are not within limits specified in first row of table 8, perform **b** below.

(10) Repeat technique of (4) through (9) above for remaining TI settings and oscilloscope calibrator outputs listed in table 8. If oscilloscope calibrator **Err** display and TI linearity are not within limits specified in table 8, perform **b** below.

Table 8. A SWP Timing

Test instrument A SWP SEC/DIV setting	Oscilloscope calibrator	
	MARKER output	Err display limit (%)
5 ns	5 nS/D	± 1.45
10 ns	10 nS/D	± 1.45
20 ns	20 nS/D	± 1.45
50 ns	50 nS/D	± 1.45
100 ns	100 nS/D	± 1.45
200 ns	200 nS/D	± 1.45
500 ns	500 nS/D	± 1.45
1 μs	1 μS/D	± 1.45
2 μs	2 μS/D	± 1.45
5 μs	5 μS/D	± 1.45
10 μs	10 μS/D	± 1.45
20 μs	20 μS/D	± 1.45
50 μs	50 μS/D	± 1.45

Table 8. A SWP Timing – Continued

Test instrument	Oscilloscope calibrator	
A SWP SEC/DIV setting	MARKER output	Err display limit (%)
100 μ s	100 μ S/D	± 1.45
200 μ s	200 μ S/D	± 1.45
500 μ s	500 μ S/D	± 1.45
1 ms	1 mS/D	± 1.45
2 ms	2 mS/D	± 1.45
5 ms	5 mS/D	± 1.45
10 ms	10 mS/D	± 1.45
20 ms	20 mS/D	± 1.45
50 ms	50 mS/D	± 1.45
100 ms	100 mS/D	± 1.45
200 ms	200 mS/D	± 1.95
500 ms	500 mS/D	± 1.95

- (11) Set **A SWP SEC /DIV** switch to **5 ms** and press **X10 MAG** pushbutton on.
- (12) Change oscilloscope calibrator output to **.5 mS/D**.
- (13) Adjust horizontal **POSITION** control to align 2^d time marker with 2^d vertical graticule line.
- (14) Rotate oscilloscope calibrator knob located below **EDIT FIELD** pushbutton to align 10th time marker with 10th vertical graticule line. If oscilloscope calibrator **Err** display does not indicate within ± 1.95 percent, perform **b** below.
- (15) Press **X10 MAG** pushbutton to off.
- (16) Set **A SWP SEC/DIV** switch to **10 ns**, and **B SWP SEC/DIV** switch to **5 ns** and push knob in for **B SWP** only.
- (17) Set oscilloscope calibrator for a **CHAN 1, MARKER** mode output of **5 ns /div**.
- (18) Adjust **TRIGGER LEVEL** control for a stable display.
- (19) Adjust horizontal **POSITION** control to align 2^d time marker with 2^d vertical graticule line.
- (20) Rotate oscilloscope calibrator knob located below **EDIT FIELD** pushbutton to align 10th time marker with 10th vertical graticule line. If oscilloscope calibrator **Err** display does not indicate within limits specified in first row of table 9, perform **b** below.
- (21) Repeat technique of (16) through (20) above for remaining TI settings and oscilloscope calibrator outputs listed in table 9. If oscilloscope calibrator **Err** display and TI linearity are not within limits specified in table 9, perform **b** below.

Table 9. B SWP Timing

Test instrument		Oscilloscope calibrator	
A SWP SEC/DIV switch setting	B SWP SEC/DIV switch setting	MARKER output	Err display limit (%)
10 ns	5 ns	5 nS/D	± 1.45
20 ns	10 ns	10 nS/D	± 1.45
50 ns	20 ns	20 nS/D	± 1.45
100 ns	50 ns	50 nS/D	± 1.45
200 ns	100 ns	100 nS/D	± 1.45
500 ns	200 ns	200 nS/D	± 1.45
1 μs	500 ns	500 nS/D	± 1.45
2 μs	1 μs	1 μS/D	± 1.45
5 μs	2 μs	2 μS/D	± 1.45
10 μs	5 μs	5 μS/D	± 1.45
20 μs	10 μs	10 μS/D	± 1.45
50 μs	20 μs	20 μS/D	± 1.45
100 μs	50 μs	50 μS/D	± 1.45
200 μs	100 μs	100 μS/D	± 1.45
500 μs	200 μs	200 μS/D	± 1.45
1 ms	500 μs	500 μS/D	± 1.45
2 ms	1 ms	1 mS/D	± 1.45
5 ms	2 ms	2 mS/D	± 1.45
10 ms	5 ms	5 mS/D	± 1.45
20 ms	10 ms	10 mS/D	± 1.45
50 ms	20 ms	20 mS/D	± 1.45
100 ms	50 ms	50 mS/D	± 1.45

(22) Set **A SWP SEC/DIV** switch to 10 ms and **B SWP SEC/DIV** switch to 5 ms and push knob in for **B SWP** only.

(23) Press **X10 MAG** pushbutton on.

(24) Change oscilloscope calibrator **MARKER** mode output to **.5 mS/D**.

(25) Adjust horizontal **POSITION** control to align 2^d time marker with 2^d vertical graticule line.

(26) Rotate oscilloscope calibrator knob located below **EDIT FIELD** pushbutton to align 10th time marker with 10th vertical graticule line. If oscilloscope calibrator **Err** display does not indicate within ± 1.95 percent, perform **b** below.

(27) Press **X10 MAG** pushbutton off.

(28) Press **Δt** pushbutton on (cursors on).

(29) Change oscilloscope calibrator **MARKER** mode output to **5 nS /D**.

(30) Set **A SWP SEC/DIV** switch to **5 ns** (knob locked).

(31) Adjust **ΔREF** or **DLY POS** control to align one cursor with 2^d time marker and **Δ** control to align other cursor with 10th time marker. If **Δt** readout indication is not within limits specified in first row of table 10, perform **b** below.

(32) Repeat technique of (29) through (31) above for remaining settings listed in table 10. If **Δt** readout indications are not within limits listed in table 10, perform **b** below.

Table 10. A SWP Cursor Timing

Test instrument A SWP/SEC/DIV switch settings	Oscilloscope calibrator output	Test instrument Δt readout indications	
		Min	Max
5 ns	5 nS/D	39.65 ns	40.35 ns
10 ns	10 nS/D	79.30 ns	80.70 ns
20 ns	20 nS/D	158.6 ns	161.4 ns
50 ns	50 nS/D	396.5 ns	403.5 ns
100 ns	.1 μ S/D	793.0 ns	807.0 ns
200 ns	.2 μ S/D	1586.0 ns	1614.0 ns
500 ns	.5 μ S/D	3965.0 ns	4035.0 ns
1 μ s	1 μ S/D	7.93 μ s	8.07 μ s
2 μ s	2 μ S/D	15.86 μ s	16.14 μ s
5 μ s	5 μ S/D	39.65 μ s	40.35 μ s
10 μ s	10 μ S/D	79.30 μ s	80.70 μ s
20 μ s	20 μ S/D	158.60 μ s	161.40 μ s
50 μ s	50 μ S/D	396.5 μ s	403.5 μ s
100 μ s	.1 mS/D	793.0 μ s	807.0 μ s
200 ms	.2 mS/D	1586.0 μ s	1614.0 us
500 μ s	.5 mS/D	3965 μ s	4035 μ s
1 ms	1 mS/D	7.930 ms	8.070 ms
2 ms	2 mS/D	15.860 ms	16.140 ms
5 ms	5 mS/D	39.65 ms	40.35 ms
10 ms	10 mS/D	79.30 ms	80.70 ms
20 ms	20 mS/D	158.60 ms	161.40 ms
50 ms	50 mS/D	396.5 ms	403.5 ms
100 ms	.1 S/D	793.0 ms	807.0 ms
200 ms	.2 S/D	1579 ms	1622 ms
500 ms	.5 S/D	3945 ms	4055 ms

- (33) Set **A SWP SEC/DIV** switch to **10 ns** and **B SWP SEC/DIV** switch to **5 ns** (knob out).
- (34) Press Δt pushbutton to off for **DLY** readout.
- (35) Press **X10 MAG** pushbutton to on.
- (36) Press **A/B TRIGGER** pushbutton for **B TRIGGER**.
- (37) Set **TRIGGER MODE** switch down to **RUN AFT DLY**.
- (38) Change oscilloscope calibrator **MARKER** mode output to **10 nS/D**.
- (39) Set **VOLTS/DIV** switch as required for a display of 3 to 6 divisions and adjust **Δ REF OR DLY POS** control for **DLY 10.64 ns**.
- (40) Adjust **TRIGGER LEVEL** control as required for a stable display.
- (41) Adjust horizontal **POSITION** control cw until the trace stops moving, then ccw to display leading edge of the 2^d time marker near graticule center.
- (42) Change oscilloscope calibrator **MARKER** mode output to **5 nS/D**.
- (43) Press Δt pushbutton to obtain Δt display and push in **SEC/DIV** knob for **B SWP** only.

TB 9-6625-2293-24

(44) Adjust Δ control for a Δt readout indication near -10.00 ns to superimpose the two time markers. If Δt readout indication is not within limits specified in first row of table 11, perform **b** below.

(45) Repeat technique of (44) above for remaining Δt readout indications listed in table 11. If Δt readout indications are not within limits specified in table 11 with the two time markers superimposed, perform **b** below.

Table 11. Delta Time Display

Test instrument		
Δt readout indications (ns)	Δt readout indication limits (ns)	
	Min	Max
-10	- 10.14	- 9.86
0.0	-0.10	0.10
10	9.86	10.14
20	19.84	20.16
30	29.80	30.20
40	39.78	40.22
50	49.74	50.26
60	59.72	60.28
70	69.68	70.32
80	79.66	80.34

(46) Press **X10** pushbutton to off. Set **A SWP SEC/DIV** switch to **20 ns** and **B SWP SEC/DIV** switch to **5 ns** (knob out).

(47) Press **X10 MAG** pushbutton on and Δt pushbutton off for **DLY** readout.

(48) Change oscilloscope calibrator **MARKER** mode output to **20 nS/D**.

(49) Adjust **Δ REF OR DLY POS** control for **DLY 21.25 ns** and horizontal **POSITION** control to position leading edge of 2^d time marker near graticule center.

(50) Change oscilloscope calibrator **MARKER** mode output to **5 nS/D**.

(51) Press Δt pushbutton to obtain a Δt display and push in **SEC/DIV** knob for **B SWP** only.

(52) Adjust Δ control for a Δt readout indication near **-20.00 ns** to superimpose the two time markers. If Δt readout indication is not between **-19.75 ns** and **-20.25 ns** with the two time markers superimposed, perform **b** below.

(53) Adjust Δ control for a Δt readout indication near **20.00 ns** to superimpose the two time markers. If Δt readout indication is not between **19.75 ns** and **20.25 ns** with the two time markers superimposed, perform **b** below.

(54) Adjust Δ control for a Δt readout indication near **160.00 ns** to superimpose the two time markers. If Δt readout indication is not between **159.30 ns** and **160.70 ns** with the two time markers superimposed, perform **b** below.

(55) Press **X10 MAG** pushbutton to off. Set **A SEC/DIV** switch to **50 ns** and **B SEC/DIV** switch to **5 ns** (knob out).

(56) Press **X10 MAG** pushbutton on and Δt pushbutton off for **DLY** readout.

- (57) Change oscilloscope calibrator **MARKER** mode output to **50 nS/D**.
- (58) Adjust **ΔREF OR DLY POS** control for **DLY 53.2 ns** and horizontal **POSITION** control to position leading edge of 2^d time marker near graticule center.
- (59) Position calibration generator controls for **5 nS/D** output.
- (60) Press **Δt** pushbutton to obtain a **Δt** display and push in **SEC/DIV** knob for **B SWP** only.
- (61) Adjust **Δ** control for a **Δt** readout indication near **-50.0 ns** to superimpose the two time markers. If **Δt** readout indication is not between **-49.30 ns** and **-50.70 ns** with the two time markers superimposed, perform **b** below.
- (62) Adjust **Δ** control for a **Δt** readout indication near **50.00 ns** to superimpose the two time markers. If **Δt** readout indication is not between **49.30 ns** and **50.70 ns** with the two time markers superimposed, perform **b** below.
- (63) Adjust **Δ** control for a **Δt** readout indication near **400.00 ns** to superimpose the two time markers. If **Δt** readout indication is not between **398.30 ns** and **401.70 ns** with the two time markers superimposed, perform **b** below.
- (64) Press **TRACK/INDEP** pushbutton for **TRACK**.
- (65) Press **X10 MAG** pushbutton to off. Set **A SWP SEC/DIV** switch to **100 ns** and **B SWP SEC/DIV** switch to **10 ns** (knob out).
- (66) Press **X10 MAG** switch on.
- (67) Change oscilloscope calibrator **MARKER** mode output to **.1 μS/D**.
- (68) Press **Δt** pushbutton on and adjust **Δ** and **ΔREF OR DLY POS** controls for a **Δt** readout of (eight times **A SWP SEC/DIV** setting) **800.0 ns**.
- (69) Adjust horizontal **POSITION** control to align leading edge of 2^d time marker on A sweep with 2^d vertical graticule line.
- (70) Adjust **TRACE SEP** control ccw to separate traces.
- (71) Adjust **ΔREF OR DLY POS** control to intensify 2^d and 10th time markers of A sweep and display leading edges of displayed B sweep time markers near center graticule line.
- (72) If horizontal distance between leading edges of B sweep time markers is not 3.4 divisions or less, perform **b** below.
- (73) Press **X10 MAG** pushbutton to off.
- (74) Set **A SWP SEC/DIV** switch to **200 ns** and set **B SWP SEC/DIV** switch to **20 ns** (knob out).
- (75) Press **X10 MAG** pushbutton on.
- (76) Change oscilloscope calibrator **MARKER** mode output to **.2 μS/D**.
- (77) Repeat technique of (68) through (72) above.
- (78) Press **X10 MAG** pushbutton to off.
- (79) Set **A SWP SEC/DIV** switch to **500 ns** and set **B SWP SEC/DIV** switch to **5 ns** (knob out).

TB 9-6625-2293-24

(80) Change oscilloscope calibrator **MARKER** mode output to **.5 μ S/D**.

(81) Adjust **Δ** and **Δ REF OR DLY POS** controls for a **Δt** readout of eight times **A SWP SEC/DIV** setting.

(82) Adjust horizontal **POSITION** control to align leading edge of 2^d time marker on A sweep with 2^d vertical graticule line.

(83) Adjust **TRACE SEP** control ccw to separate traces.

(84) Adjust **Δ REF OR DLY POS** control to intensify 2^d and 10th time markers of A sweep and display leading edges of displayed B sweep time markers in center area of graticule.

(85) If horizontal distance between leading edges of B sweep time markers is not 3.4 divisions or less, perform **b** below.

(86) Repeat technique of (79) through (85) above for settings listed in table 12. If horizontal distance between leading edges of B sweep time markers is not 3.4 divisions or less, except where noted, perform **b** below.

Table 12. Delayed Sweep Delta Time

Oscilloscope calibrator output settings	Test instrument	
	A SWP SEC/DIV switch settings	B SWP SEC/DIV switch settings
1 μ S/D	1 μ s	10 ns
2 μ S/D	2 μ s	20 ns
5 μ S/D	5 μ s	50 ns
10 μ S/D	10 μ s	100 ns
20 μ S/D	20 μ s	200 ns
50 μ S/D	50 μ s	500 ns
.1 mS/D	100 μ s	1 μ s
.2 mS/D	200 μ s	2 μ s
.5 mS/D	500 μ s	5 μ s
1 mS/D	1 ms	10 μ s
2 mS/D	2 ms	20 μ s
5 mS/D	5 ms	50 μ s
10 mS/D	10 ms	100 μ s
20 mS/D	20 ms	200 μ s
50 mS/D	50 ms	500 μ s
.1 mS/D	100 ms	1 ms
.2 mS/D	200 ms	2 ms ¹
.5 mS/D	500 ms	5 ms ¹

¹7.4 divisions or less.

b. Adjustments. Refer to **SECTION IV** below.

12. Bandwidth

a. Performance Check

- (1) Press **TRACK/INDEP** pushbutton for **INDEP**.
- (2) Press **Δt** pushbutton off.

- (3) Set **CH1** and **CH 2** input coupling switches down to **50 Ω DC**.
- (4) Set **A SWP SEC/DIV** switch for **50 μs** (knob in). Adjust **TRACE SEP** control fully cw.
- (5) Set **CH 1 VOLTS/DIV** switches to **2 mV**.
- (6) Press **VERTICAL MODE CH 1** pushbutton on and **VERTICAL MODE CH 2, 3** and **4** pushbuttons off.
- (7) Set **TRIGGER SOURCE** switch up to **VERT CH 1**.
- (8) Set oscilloscope calibrator for a **CHAN 1, LEVEL SINE** mode output of **50 kHz** and adjust amplitude for 6 divisions of vertical display on **TI**.

NOTE

To perform steps (9), (12), (19) and (23) below; press oscilloscope calibrator **EDIT FIELD** pushbutton as required to place underline under one of the frequency digits.

- (9) Increase oscilloscope calibrator frequency until display is 4.25 divisions. If oscilloscope calibrator frequency is not 100 MHz or greater, perform **b** below.
- (10) Set **CH 1 VOLTS/DIV** switch to **20 mV**.
- (11) Set oscilloscope calibrator **CHAN 1, LEVEL SINE** mode output for a 6 division display at 50 kHz.
- (12) Increase oscilloscope calibrator frequency until display is 4.25 divisions. If oscilloscope calibrator frequency is not 300 MHz or greater, perform **b** below.
- (13) Set **CH 1 VOLTS/DIV** switch to **500 mV**. Repeat technique of (11) and (12) above.
- (14) Press **VERTICAL MODE CH 1** pushbutton off and **VERTICAL MODE CH 2** on.
- (15) Set **CH 2 VOLTS/DIV** switch to **2 mV**, and repeat technique of (7) through (13) above for **CH 2**.
- (16) Insert 50 Ω feedthrough terminations on **TI CH 3** and **CH 4** connections.
- (17) Press **VERTICAL MODE CH 2** pushbutton off and **VERTICAL MODE CH 3** on. Press **CH 3 VOLTS/DIV** pushbutton for **0.1 V**.
- (18) Set oscilloscope calibrator **CHAN 3, LEVEL SINE** mode output for a 6 division display at 50 kHz.
- (19) Increase oscilloscope calibrator frequency until display is 3.5 divisions. Oscilloscope calibrator frequency will be 300 MHz or greater.
- (20) Press **VERTICAL MODE CH 3** pushbutton to off and **VERTICAL MODE CH 4** to on.
- (21) Press **CH 4 VOLTS/DIV** pushbutton for **0.1 V**.
- (22) Set oscilloscope calibrator **CHAN 4, LEVEL SINE** mode output for a 6 division display at 50 kHz.
- (23) Increase oscilloscope calibrator frequency until display is 3.5 divisions. Oscilloscope calibrator frequency will be 300 MHz or greater.

TB 9-6625-2293-24

b. Adjustments. Refer to **SECTION IV** paragraph **22** below.

13. Calibrator

a. Performance Check

- (1) Press corresponding pushbuttons for indications as listed in (a) and (b) below:
 - (a) **VERTICAL MODE CH 1** on and **VERTICAL MODE CH 2, CH 3** and **CH 4** off.
 - (b) **CH 1** input coupling switch up to **1 M Ω DC**.
- (2) Set **CH 1 VOLTS/DIV** switch to **100 mV**, and **VAR** controls fully cw to detent.
- (3) Set **A SWP** and **B SWP SEC/DIV** switch to **1 ms** (knobs locked) and **SEC/DIV VAR** control fully cw to detent.
- (4) Position **TRIGGER HOLDOFF** control to **B ENDS A** fully cw to detent.
- (5) Connect **TI CH 1** to **TI CALIBRATOR** terminal and adjust **CH 1 VERTICAL POSITION** control as necessary to view signal.
- (6) Adjust **TI CH 1 VOLTS/DIV VAR** control for 4 divisions of vertical deflection on **TI** (do not change setting).
- (7) Move connection at **TI** calibrator to oscilloscope calibrator **CHAN 1**.
- (8) Set oscilloscope calibrator for a **CHAN 1, VOLTAGE** mode output of **400 mV** at 1 kHz frequency.
- (9) Adjust **TI A TRIGGER LEVEL, CH 1 \updownarrow POSITION** and **\Leftarrow POSITION \Rightarrow** controls as necessary to view waveform.
- (10) Rotate oscilloscope calibrator knob below **EDIT** field pushbutton to adjust waveform to 4 divisions of vertical deflection on **TI**. If oscilloscope calibrator **Err** display is not within ± 1 percent, perform **b** below.

b. Adjustments. Refer to **SECTION IV** below.

14. Final Procedure

- a.** Deenergize and disconnect all equipment.
- b.** Annotate and affix DA label/form in accordance with TB 750- 25.

**SECTION IV
MENU CALIBRATION PROCESS**

15. Preliminary Instructions

a. The procedures in paragraph **17** through **22** should be performed only if an out-of-tolerance condition exists in paragraphs **8** through **13** or if an error message on the bottom line of the crt display is **TEST 04 xx**, where **xx** is **01, 02, 10, or 11** when **POWER** pushbutton is pressed to **ON**.

b. When performing paragraphs **19** through **22** touch only specific control or controls called out in the procedure. Movement of any other control may cause erroneous calibration results.

c. Within the automatic calibration procedure, the calibration constants for timing, vertical gain, and trigger level are generated by the system microprocessor and stored in nonvolatile memory. The adjustments in **CAL 01, 02, 03** should be done in numerical sequence.

d. When performing automatic **CAL** steps, initial setting of front-panel controls is not required.

16. Equipment Setup

WARNING

HIGH VOLTAGE is used or exposed during the performance of this calibration. DEATH ON CONTACT may result if personnel fail to observe safety precautions. REDUCE OUTPUT(S) to minimum after each step within the performance check where applicable.

a. Press **TI POWER** pushbutton to **OFF** and disconnect TI from the 115 V ac source. Remove protective cover and move **CAL/NO CAL** jumper (P501) on A5 control board (right side of TI) to **CAL** position.

b. Connect TI to a 115 V ac source and press **POWER** pushbutton to **ON** and allow at least 20 minutes for equipment warm-up.

NOTE

When **POWER** pushbutton is pressed to **ON**, TI automatically performs a self-test sequence. Upon successful completion of self-test, TI will be in normal operating mode.

NOTE

Throughout this procedure, readout and control messages are displayed along the top and bottom of display (crt).

c. Adjust corresponding controls for indications as listed in (1) through (8) below:

- (1) **VERTICAL MODE CH 1, CH 2, CH 3, and CH 4** on.
- (2) **CH 3 and CH 4 VOLTS/DIV** for **.1 V**.
- (3) **VERTICAL MODE ADD, INVERT, and 20 MHz BW LIMIT** off.
- (4) **VERTICAL MODE CHOP/ALT** to **ALT**.
- (5) **VERTICAL MODE CH 3 and CH 4** off.
- (6) **TRIGGER SLOPE** to + (plus).
- (7) **TRACK/INDEP** to **INDEP**.
- (8) **Δt and ΔV** to off (no cursors on display).

TB 9-6625-2293-24

d. Set corresponding switches up or down for indications as listed in (1) through (4) below:

- (1) **CH 1** and **CH 2** input coupling for **1 M Ω DC**.
- (2) **TRIGGER MODE** to **AUTO LVL**.
- (3) **TRIGGER SOURCE** to **VERT**.
- (4) **TRIGGER COUPLING** to **DC**.

e. Position controls as listed in (1) through (8) below:

- (1) **VERTICAL POSITION** controls to midrange.
- (2) Horizontal **POSITION** control to midrange.
- (3) **TRIGGER LEVEL** control to midrange.
- (4) **TRIGGER HOLDOFF** control fully cw to **B ENDS A** detent.
- (5) **SCALE ILLUM** control fully ccw.
- (6) **CH 1** and **CH 2 VOLTS/DIV** switches to **1 00 mV** and **VAR** control fully cw to detent.
- (7) **A SWP SEC/DIV** switch to **100 μ s** (knobs locked) and **VAR** control cw to detent.
- (8) **INTENSITY**, **FOCUS**, and **READOUT INTENSITY** controls for suitable viewing.

17. Power Supply

a. Performance Check

- (1) Press **VERTICAL MODE** pushbutton **CH 2** to off.
- (2) Connect multimeter **LO** to chassis ground and **HI** to TI J119 (fig. 1) pin 4. If multimeter does not indicate between +9.99 and +10.01 V dc, perform **b** below.

b. Adjustments. Adjust VOLT REF ADJ R1292 (fig 2) until multimeter indicates 10.00 V DC (R).

18. DAC REF and Input Capacitance

a. Performance Check

- (1) Press **Δ t** pushbutton for a **Δ t** display on crt.
- (2) Connect multimeter **LO** to chassis ground and **HI** to J118 (fig 1) pin 2.
- (3) Rotate **Δ REF OR DLY POS** control ccw until multimeter indication remains at a constant value (approximately -1.25 V dc). Record indication.
- (4) Rotate **Δ REF OR DLY POS** control cw until multimeter indication remains at a constant value (approximately 1.25 V dc). Record indication.
- (5) Add the absolute values of indications recorded in (3) and (4) above (approximately 2.500 V).
- (6) Subtract the total in (5) above from 2.500 V, then divide the difference by two.

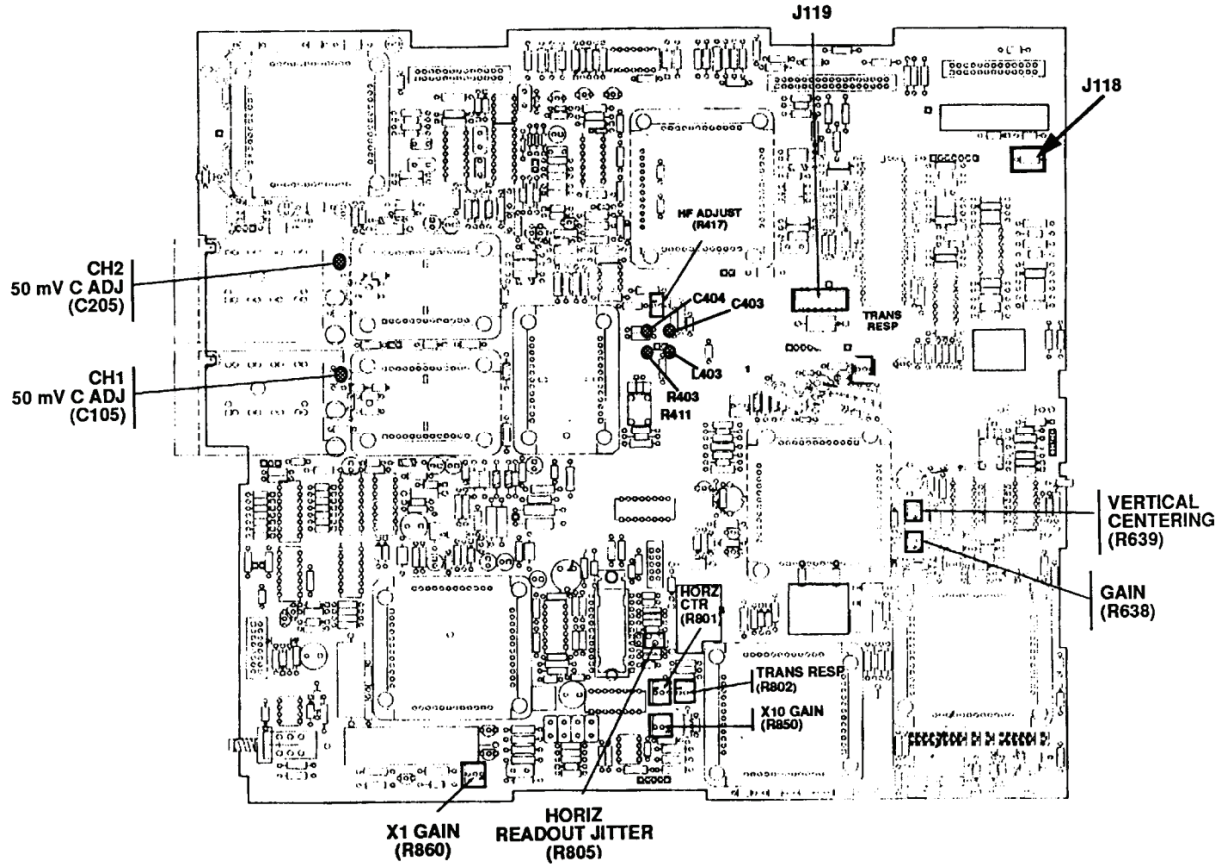

Figure 1. A1 main board - adjustment locations.

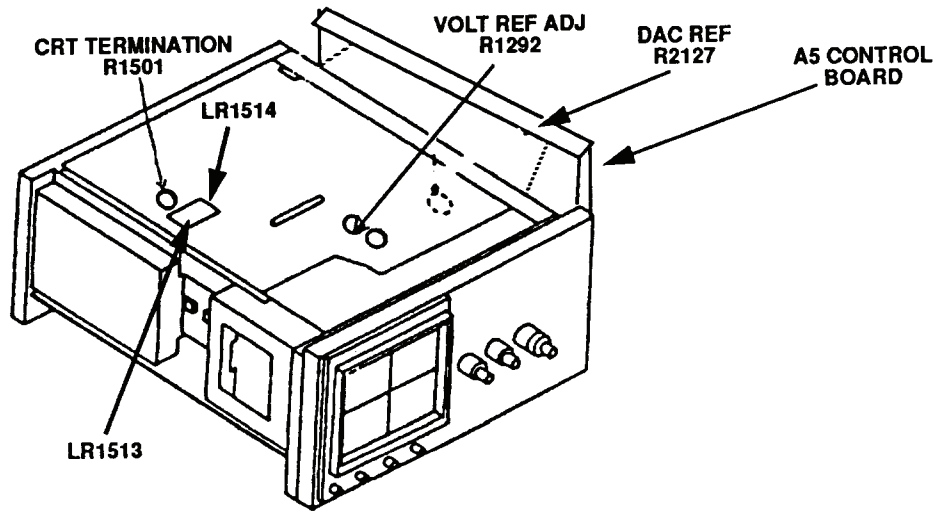

Figure 2. Adjustment locations.

TB 9-6625-2293-24

- (7) Adjust DAC REF R2127 (fig 2) to add the (signed) number obtained in (6) above to the reading in (4) above.
- (8) Repeat (3) through (7) above as necessary to obtain a total DAC range of 2.500 V.
- (9) Disconnect multimeter.
- (10) Press Δt pushbuttons to off (no cursor on display).
- (11) Connect oscilloscope calibrator **SOURCE/MEASURE CHAN 1** to **TI CH 1** using a 5-80 pF standardizer.
- (12) Set oscilloscope calibrator for a **CHAN 1, EDGE** mode output of **600 mV** at 1 kHz frequency.
- (13) Rotate oscilloscope calibrator knob below **EDIT** field pushbutton to adjust waveform to 6 divisions of vertical deflection on TI.
- (14) Adjust 5-80 pF standardizer for a square front corner over the first 40 μ s (0.4 division) of the positive portion of waveform. Note waveform front corner for use in (17) below.
- (15) Change oscilloscope calibrator **EDGE** mode output to **300 mV** at 1 kHz.
- (16) Set **VOLTS/DIV** switch to **50 mV** and rotate oscilloscope calibrator knob below **EDIT** field pushbutton to adjust waveform to 6 divisions of vertical deflection on TI.
- (17) Adjust CH1 50 mV C ADJ (C105) and CH2 50 mV C ADJ (C205) for CH 2 (fig 1) for same waveform front corner as noted in (14) above.
- (18) Set **VOLTS/DIV** switch to **100 mV**.
- (19) Repeat (13) through (18) above until no change is observed in the waveform front corner.
- (20) Press **VERTICAL MODE CH 1** to off and **CH 2** to on.
- (21) Repeat technique of (11) through (19) above for **CH 2**.

19. CAL 01 Horizontal

a. Performance Check

- (1) Simultaneously press and hold Δt and ΔV pushbuttons; then press and hold **TRIGGER SLOPE** pushbutton. Hold in all three pushbuttons for approximately 1 second and then release. Top of display will indicate: **DIAGNOSTIC. PUSH A/B TRIG TO EXIT.**
- (2) Push **TRIGGER MODE** switch up to step to **CAL 01** (lower left corner of display).

CAUTION

Upon entering **CAL 01**, the input coupling is automatically set to **50 Ω DC** and **50 Ω** overload protection is disabled. Before starting procedure, make sure any 50 Ω overload condition has been cleared.

NOTE

In this procedure, pressing up and releasing **TRIGGER COUPLING** switch stores current calibration parameter being set and increments routine to next step (except where otherwise noted).

NOTE

Throughout this paragraph the **INTENSITY** and **POSITION** controls may be adjusted as necessary for proper viewing of displayed signal.

- (3) Connect multimeter **LO** to chassis ground and **HI** to **TI CALIBRATOR** output (front panel).
- (4) Set multimeter to measure dc volts.
- (5) Push up and release upper **TRIGGER COUPLING** switch. The display readout will indicate **ADJ Δ**, (step) 1, **100 μs** and **1 μs**.
- (6) Multimeter indication will be 0 mV ±1 mV.
- (7) Set oscilloscope calibrator for a **CHAN 1, MARKER** mode output of **.1 ms/div**.
- (8) Set **VOLTS/DIV** switch as needed for a convenient signal amplitude.
- (9) Adjust **TRACE SEP** control as needed to separate the A and B sweeps.
- (10) Adjust **CH 1 POSITION** control as needed to view both A and B sweeps.
- (11) Adjust **HORIZONTAL POSITION** control to start trace at the left graticule line.
- (12) Adjust **ΔREF OR DLY POS** and **Δ** controls to align both intensified zones with the 6th time marker near graticule center and to superimpose the delayed B sweep time markers.
- (13) Push up and release **TRIGGER COUPLING** switch. Check multimeter indicates between 398 mV and 402 mV and TI readout indicates **ADJ Δ** (step) 2, **100 μs**, **1 μs**.
- (14) Disconnect multimeter from TI and adjust **ΔREF OR DLY POS** control to intensify 2^d time marker.
- (15) Adjust **Δ** control to intensify 10th time marker and superimpose delayed B sweep time markers within .2 division.
- (16) Push up and release **TRIGGER COUPLING** switch.
- (17) Display readout will indicate **ADJ Δ**, (step) 3, **300 μs**, **1 μs**.
- (18) Adjust **ΔREF OR DLY POS** control to intensify 4th time marker and **Δ** control to intensify 28th time marker and superimpose delayed B sweep markers within 1.2 division.
- (19) Push up and release **TRIGGER COUPLING** switch.

NOTE

If adjustments are made in (18) above, display readout will indicate **ADJ Δ** (step) 2, **200 μs**, **1 μs**. Repeat (14) through (19) above until no adjustments are made in (18) above.

TB 9-6625-2293-24

(20) If no adjustments were made in (18) above, display readout will indicate **ADJ Δ**, (step) **4, 100 μs, 1 μs**.

(21) Change oscilloscope calibrator **MARKER** mode output to **5 μS/D**.

(22) Adjust **Δ** control ccw until no further movement of B sweep display occurs. Note position of first time marker of B sweep.

(23) Adjust **Δ** control cw until 2^d time marker of B sweep moves left and aligns with position noted in (22) above.

NOTE

Movement of **ΔREF OR DLY POS** control at this point will adversely affect calibration.

(24) Push up and release **TRIGGER COUPLING** switch. Display readout will indicate **X1, X10, HRZ CTR**, (step) **5, 10 μs** and two vertical cursors appears on the display.

(25) Change oscilloscope calibrator **MARKER** mode output to **10 μS/D**.

(26) If cursors are not aligned with 2^d and 10th vertical graticule lines, adjust **X1 GAIN** (R860) (fig 1), and **HORZ CTR** (R801) (fig 1) to align the two cursors with 2^d and 10th vertical graticule line (R).

(27) If TI does not display 1 time marker per division ± 1 minor division, adjust **X10 GAIN** (R850) (fig. 1) for 1 marker per division (R).

(28) Push up and release **TRIGGER COUPLING** switch. Display readout will indicate **ADJ Δ**, (step) **6, 10 ms, 100 μs**.

(29) Change oscilloscope calibrator **MARKER** mode output to **10 mS/D** and adjust **ΔREF OR DLY POS** control to intensify 2^d time marker and **Δ** control to intensify 10th time marker, and superimpose delayed B sweep time markers within .2 division.

(30) Push up and release **TRIGGER COUPLING** switch, and position calibration generator controls for **1 μS/D** output.

(31) For each step in table 13 do the following:

(a) Adjust **ΔREF OR DLY POS** and **Δ** controls as necessary, to intensify indicated time markers on the A sweep and superimpose displayed B sweep time markers within listed limits.

(b) Push up and release **TRIGGER COUPLING** switch.

(32) After completion of step 16 of table 13 TI display will indicate **ADJ Δ**, (step) **17, 1 μs**.

(33) Adjust **TRACE SEP** control fully cw.

(34) For each step in table 14 (except step 28) adjust **Δ** control for listed number of time markers over center 8 divisions then push up and release **TRIGGER COUPLING** switch.

Table 13. Timing (CAL 01 Steps 7 Through 16)

Display step number	Test instrument		Oscilloscope calibrator output settings	Test instrument superimposed displayed B sweep \pm division
	Δ REF time marker	Δ t marker		
7	2	10	1 μ S/D	0.2
8	2	10	2 μ S/D	0.2
9 ¹	4	28	2 μ S/D	1.2
10	2	10	10 μ S/D	0.2
11	2	10	50 μ S/D	0.2
12 ¹	4	28	50 μ S/D	1.2
13	2	10	0.5 μ S/D	0.2
14 ¹	4	28	0.5 μ S/D	1.2
15	2 ²	10	0.1 μ S/D	0.2
16	2 ²	10	20 nS/D	0.1

¹If Δ control is adjusted at step **9**, **12**, or **14** the previous step will be repeated.

²Intensify starts on indicated time marker and may cover more than 1 time marker.

Table 14. Timing (CAL 01 Steps 17 Through 29)

Displayed Step	Test instrument		Oscilloscope calibrator output settings
	Time markers over 8 divisions		
17	8		1 μ S/D
18	24		1 μ S/D
19	8		2 μ S/D
20	24		2 μ S/D
21	8		10 μ S/D
22	8		50 μ S/D
23	24		50 μ S/D
24	8		0.5 μ S/D
25	24		0.5 μ S/D
26	8		0.1 μ S/D
27	8		20 nS/D
28	2		2 nS/D
29	8		1 mS/D

NOTE

If Δ control is adjusted at step **18**, **20**, **23** or **25** the previous step will be repeated. At step **28**, adjust TRANS RESP R802 (fig 1) for precisely two cycles between the 2^d and 10th graticule lines.

(35) After step 29 has been completed display will indicate **DIAGNOSTIC PUSH A/B TRIG TO EXIT**.

20. CAL 02 -Vertical

a. Performance Check

- (1) Set **TRIGGER MODE** switch up to step to **CAL 02** (bottom left of display).

TB 9-6625-2293-24

- (2) Push up and release **TRIGGER COUPLING** switch. TI will step from 100 to 111 and display will indicate **CH 1 VAR, CH 2 POS**, (step) **111, 500 mV**.
- (3) Set oscilloscope calibrator for a **CHAN 1, VOLTAGE** mode output of **.5 V** at 1 kHz frequency.
- (4) Adjust **CH 2 POSITION** control to position sweep within 1 division of center horizontal graticule line.
- (5) Adjust **CH 1 POSITION** and **VOLTS/DIV VAR** controls for 10 divisions of horizontal deflection.
- (6) Push up and release **TRIGGER COUPLING** switch. Display readout will indicate (step) **MOVE SW, CENTER CH 1 POS**, (step) **112, 500 mV**, and **BWL**.
- (7) Push up and release **TRIGGER COUPLING** switch.
- (8) Adjust **CH 1 POSITION** control until **CH 1** input coupling **1 M Ω DC** indicator remains illuminated. Push up and release **TRIGGER COUPLING** switch.

NOTE

In the following steps, if the **LIMIT** message appears, it probably indicates that the upper **TRIGGER COUPLING** switch was pushed before the required signal was applied. Push down and release **TRIGGER COUPLING** switch, verify that the correct signal is applied, and then push up and release **TRIGGER COUPLING** switch.

- (9) Display readout will indicate first step number listed in table 15.
- (10) Push up and release **TRIGGER COUPLING** switch for TI step numbers and calibration generator output settings as listed in table 15.

Table 15. Vertical Attenuator Check

Test instrument CAL 02 step numbers	Oscilloscope calibrator output settings
113,114 ¹	.5 V
115	.2 V
116	.1 V
117	50 mV
118	20 mV
119	1 V
120	10 V

¹When step 113 is performed, step 114 is automatically done. No indication of step 114 will be shown unless a **LIMIT** error is encountered.

- (11) After step 120 is performed display readout will indicate **MOVE SW, CENTER CH 2 POS** step **121, 500 mV, 500 mV**, and **BWL**.
- (12) Move connection from **CH 1** to **CH 2**.
- (13) Set oscilloscope calibrator for a **CHAN 1, VOLTAGE** mode output of **.5 V** at 1 kHz frequency.

- (14) Push up and release **TRIGGER COUPLING** switch.
- (15) Adjust **CH 2 VERTICAL POSITION** control until **CH 1** input coupling **1 M Ω DC** indicator remains illuminated, then push up and release **TRIGGER COUPLING** switch.
- (16) Display readout will indicate **MOVE SW, CENTER CH 2 POS** step **122, 500 mV, 500 mV** and **BWL**.
- (18) Push up and release **TRIGGER COUPLING** switch.
- (19) Adjust **CH 2 VERTICAL POSITION** control until **CH 1** input coupling **1 M Ω DC** indicator remains illuminated, then push up and release **TRIGGER COUPLING** switch.
- (20) Display readout will indicate first **CAL 02** step number listed in table 16, (123, 124).
- (21) For each step number listed in table 16 apply corresponding calibration generator output, then push up and release **TRIGGER COUPLING** switch.

Table 16. Vertical Attenuator Check

Test instrument CAL 02 Step numbers	Oscilloscope calibrator output settings
123,124 ¹	0.5 V
125	0.2 V
126	0.1 V
127	50 mV
128	20 mV
129	1 V
130	10 V

¹When step 123 is performed, step 124 is also automatically done. No indication of step 124 will be shown unless a **LIMIT** error is encountered.

- (22) After step 130 is completed display readout will indicate **MOVE SW, CENTER CH 2 POS**, step **131, 10 V**, [arrow down] **10 V**, and **BWL**.
- (23) Push up and release **TRIGGER COUPLING** switch.
- (24) Adjust **CH 2 VERTICAL POSITION** control until **CH 1** input coupling **1 M Ω DC** indicator remains illuminated, then push up and release **TRIGGER COUPLING** switch. The TI will automatically increment through steps 132 to 142.
- (25) Display readout will indicate **MOVE SW, CENTER CH 1 POS** step **142, 50 mV** and **BWL**.
- (26) Move connection from **CH 2** to **CH 1** and set oscilloscope calibrator for a **50 mV** 1 kHz output, then push up and release **TRIGGER COUPLING** switch.
- (27) Adjust **CH 1 VERTICAL POSITION** control until **CH 1** input coupling **1 M Ω DC** indicator remains illuminated, then push up and release **TRIGGER COUPLING** switch. Wait approximately 10 seconds for automatic calibration of the **ΔV** cursors.
- (28) Display readout will indicate **VERTICAL CENTER** and **GAIN**.
- (29) Adjust **VERTICAL CENTERING R639** (fig. 1) to center cursors on the 0 percent and 100 percent dotted graticule lines.

TB 9-6625-2293-24

(30) Push up and release **TRIGGER COUPLING** switch. Display readout will indicate **DIAGNOSTIC PUSH A/B TRIG TO EXIT**.

21. CAL 03 Triggering

a. Performance Check

- (1) Set **TRIGGER MODE** switch up to step to **CAL 03** (bottom left of display).
- (2) Push up and release **TRIGGER COUPLING** switch.
- (3) TI automatically steps from 201 through 214 and stops at 215 and display readout indicates **CH 1, 500 mV, (step) 215**.
- (4) Connect oscilloscope calibrator **SOURCE/MEASURE CHAN 1** to TI **CH 1**.
- (5) Set oscilloscope calibrator for a **CHAN 1, VOLTAGE** mode output of **.5 V** at 1 kHz frequency.
- (6) Push and release **TRIGGER COUPLING** switch. Display readout will indicate **CH 1, 500 mV, (step) 216**.
- (7) Push up and release **TRIGGER COUPLING** switch. Display readout will indicate **CH 2, 500 mV, (step) 217**.
- (8) Move connection from **CH 1** to **CH 2** and repeat (5) above.
- (9) Push and release **TRIGGER COUPLING** switch. Display readout will indicate **CH 3, 500 mV, (step) 218**.
- (10) Move connection from **CH 2** to **CH 3** and repeat (5) above.
- (11) Push and release **TRIGGER COUPLING** switch. Display readout will indicate **CH 3, 2 V, (step) 219**.
- (12) Change oscilloscope calibrator **VOLTAGE** mode output to **2 V**.
- (13) Push and release **TRIGGER COUPLING** switch. Display readout will indicate **CH 4, 500 mV, (step) 220**.
- (14) Move connection from **CH 3** to **CH 4**.
- (15) Change oscilloscope calibrator **VOLTAGE** mode output to **.5 V**.
- (16) Push and release **TRIGGER COUPLING** switch. Display will indicate **CH 4, 2 V, (step) 221**.
- (17) Change oscilloscope calibrator **VOLTAGE** mode output to **2 V**.
- (18) Push and release **TRIGGER COUPLING** switch. Display will indicate **DIAGNOSTIC. PUSH AB TRIG TO EXIT**.
- (19) Press **A/B TRIG** pushbutton to exit, press **POWER** pushbutton to **OFF**, and move **CAL/ NO CAL** jumper to **NO CAL** position, press **POWER** pushbutton to **ON**.

22. CAL 06 Vertical Transient Response

a. Performance Check

- (1) Press corresponding pushbutton for indications as listed in (a) through (g) below:

- (a) **VERTICAL MODE CH 1** and **CH 2** to on.
 - (b) **VERTICAL MODE CH 3** and **CH 4** to off.
 - (c) **ADD, INVERT**, and **BW LIMIT** to off.
 - (d) **ALT/CHOP** to **ALT**.
 - (e) **TRIGGER SLOPE** to + (plus).
 - (f) **TRACKING/INDEP** to **INDEP**.
 - (g) **ΔV** to on (**RATIO** readout).
- (2) Set corresponding switch up or down for indications as listed in (a) through (d) below:
- (a) **TRIGGER MODE** to **AUTO LVL**.
 - (b) **TRIGGER SOURCE** to **VERT**.
 - (c) **TRIGGER COUPLING** to **DC**.
 - (d) **CH 1** and **CH 2** input coupling to **50 Ω DC**.
- (3) Position corresponding controls for indications as listed in (a) through (m) below:
- (a) **CH 1** and **CH 2 VOLTS/DIV** to **10 mV**.
 - (b) **CH 1 VAR** ccw (out of detent).
 - (c) **CH 2 VAR** cw to detent.
 - (d) **CH 1** and **CH 2 VERTICAL POSITION** to midrange.
 - (e) **A** and **B SEC/DIV** to **20 ns** (knobs locked).
 - (f) **A** and **B SEC/DIV VAR** to detent.
 - (g) Horizontal **POSITION** to midrange.
 - (h) **TRIGGER LEVEL** to midrange.
 - (i) **TRIGGER HOLDOFF** to detent.
 - (j) **ΔREF OR DLY POS** and **Δ** to place cursors near the 3^d line above and 3^d line below graticule center (6 division spacing).
 - (k) **INTENSITY** control to left of center.
 - (l) **READOUT INTENSITY** to right of center.
 - (m) **FOCUS** for best focused display.

NOTE

Crt termination, high frequency transient response, vertical gain, vertical centering, and readout jitter adjustments are interactive. This procedure optimizes these adjustments together.

- (4) Press **CH 2** pushbutton off and adjust **CH 1 VOLTS/DIV VAR** control for a **RATIO** readout.
- (5) Adjust **ΔREF OR DLY POS** control ccw until **RATIO** readout is constant (>130 percent).
- (6) Adjust **Δ** control until readout display indicates 130.0 percent.
- (7) One cursor should be near bottom horizontal graticule line and the other cursor near dotted graticule line marked 100(percent).
- (8) Adjust **ΔREF OR DLY POS** control until the readout displays 100.0 percent. Cursors should now be on or near dotted graticule lines marked 0 percent and 100 percent.

TB 9-6625-2293-24

- (9) Return **CH 1 VOLTS/DIV VAR** control to detent position.

NOTE

Controls adjusted in (4) through (7) above should not be moved during the balance of this procedure. If they are accidentally moved, repeat the procedure from the beginning.

- (10) Connect oscilloscope calibrator **SOURCE/MEASURE CHAN 1** to **TI CH 1** using a **X10**, and **X2** attenuator.

- (11) Set oscilloscope calibrator for a **CHAN 1, EDGE** mode output of **600 mV** at 100 kHz frequency.

- (12) Adjust **TRIGGER LEVEL** control for a stable display and rotate oscilloscope calibrator knob below **EDIT** field pushbutton to adjust waveform to 5 divisions of vertical deflection on **TI**.

- (13) Adjust **CRT TERMINATION R1501** (fig 2) for best flat top approximately 5 ns past rising edge of waveform. Squeezing the output leads of the termination inductors (**LR1513** and **LR1514**) (fig. 2) toward each other will reduce the spike which may be present approximately 6 ns behind the leading edge.

- (14) Adjust **C404** and **R403** (fig 1) alternately for best flat top on first 10 ns of waveform.

- (15) Repeat technique of (12) and (13) above as necessary for best flat top over first 20 ns of waveform.

- (16) Adjust **GAIN (R638)** (fig 1) and **VERTICAL CENTERING (R639)** (fig. 1) to align cursors with dotted 0 percent and 100 percent graticule lines.

- (17) Press **ΔV** pushbutton off (cursors off).

- (18) Adjust **R411, C403, and HF ADJUST R417** (fig. 1) alternately for best square front corner and best flat top of waveform. If front corner is overshoot, adjust small coil **L403** (fig. 1) by spreading coil leads apart, then readjust **R411** and **C403** (fig. 1).

- (19) Move connection from **CH 1** to **CH 2**.

- (20) Press **VERTICAL MODE CH 1** pushbutton to off and **VERTICAL MODE CH 2** pushbutton to on.

- (21) Repeat technique of (14) and (18) above for **CH 2**. Switch between **CH 1** and **CH 2** as necessary, until both **CH 2** and **CH 1** aberrations are minimized. When minimized, leave **CH 2** selected.

- (22) Connect oscilloscope calibrator **SOURCE/MEASURE CHAN 1** to **TI CH 2**.

- (23) Set oscilloscope calibrator **LEVEL SINE** mode for a **50 kHz** output and adjust amplitude for 6 divisions of vertical deflection. Adjust **A** and **B SEC/DIV** switch and **CH 2 POSITION** controls for suitable viewing.

NOTE

To perform step below; press oscilloscope calibrator **EDIT FIELD** pushbutton as required to place underline under one of the frequency digits.

(24) Increase oscilloscope calibrator frequency to 300 MHz. Display amplitude should be between 4.5 and 5 divisions.

(25) Sweep oscilloscope calibrator frequency from 300 to 250 MHz. If display amplitude is not 4.4 divisions or greater, make necessary compromises to settings in (14) and (18) above to obtain best flat top with proper bandwidth. HF ADJUST (R417) (fig. 1) will have most effect on bandwidth.

(26) Move connection from TI **CH 2** to TI **CH 1** and press **VERTICAL MODE CH 1** pushbutton to on and **CH 2 VERTICAL MODE CH 2** off.

(27) Repeat technique of (22) through (25) for **CH 1**.

(28) If readjustment of HF ADJ R417 (fig. 1) was necessary, repeat (13) through (25) above.

23. Final Procedure

- a. Press **POWER** pushbutton to **OFF**, and replace protective cover.
- b. Press **POWER** pushbutton to **ON** and repeat paragraphs 7 through 13.

By Order of the Secretary of the Army:

Official:



JOYCE E. MORROW
*Administrative Assistant to the
Secretary of the Army*

0726809

GEORGE W. CASEY, JR.
*General, United States Army
Chief of Staff*

Distribution:

To be distributed in accordance with the initial distribution number (IDN) 344488, requirements for calibration procedure TB 9-6625-2293-24.

INSTRUCTIONS FOR SUBMITTING AN ELECTRONIC 2028

The following format must be used if submitting an electronic 2028. The subject line must be exactly the same and all fields must be included; however, only the following fields are mandatory: 1, 3, 4, 5, 6, 7, 8, 9, 10, 13, 15, 16, 17, and 27.

From: "Whomever" whomever@redstone.army.mil
To: <2028@redstone.army.mil

Subject: DA Form 2028

1. **From:** Joe Smith
2. **Unit:** home
3. **Address:** 4300 Park
4. **City:** Hometown
5. **St:** MO
6. **Zip:** 77777
7. **Date Sent:** 19-OCT -93
8. **Pub no:** 55-2840-229-23
9. **Pub Title:** TM
10. **Publication Date:** 04-JUL-85
11. **Change Number:** 7
12. **Submitter Rank:** MSG
13. **Submitter FName:** Joe
14. **Submitter MName:** T
15. **Submitter LName:** Smith
16. **Submitter Phone:** 123-123-1234
17. **Problem:** 1
18. **Page:** 2
19. **Paragraph:** 3
20. **Line:** 4
21. **NSN:** 5
22. **Reference:** 6
23. **Figure:** 7
24. **Table:** 8
25. **Item:** 9
26. **Total:** 123
27. **Text**

This is the text for the problem below line 27.

